

M40 ANALOGUE SENSOR FOR PICANOL-GTM RAPIER WEAVING MACHINE

**4...11 mm
SHIELDED**

OPERATIONAL DATA:

1. INSTALLATION IN METAL	SHIELDED
2. SENSING DISTANCE with FeST37- 40mm x 40mm x 1mm Plate	4...11mm
3. LINEARITY	3%
4. HYSTERESIS	0.03mm
5. REPEATABILITY	0.02mm
6. TEMPERATURE DRIFT	0.2% over operating range.
7. AMB. TEMP. RANGE	0 DEG.C. TO 70 DEG.C.

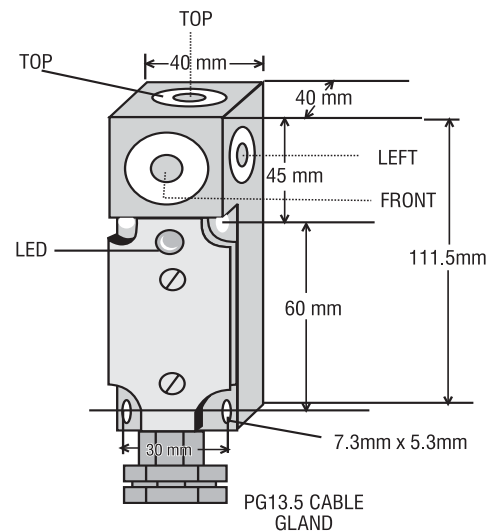

ELECTRICAL DATA:

8. OPERATING VOLTAGE	13.5 V TO 30 VDC
9. CURRENT CONSUMPTION	<15 mA
10. OUTPUT VOLTAGE	0 V.....10V OVER FULL RANGE
11. SWITCHING FREQUENCY	190 Hz
12. LOAD CURRENT (MAXIMUM)	20 mA
13. OUTPUT TYPE	PNP ANALOGUE
14. LOAD RESISTANCE	>=4.7KOhm

ORDERING CODE Eqv. to PICANOL PART NO:

PSIBL40ANFVCB03RS BE -89270
PNP/4..11mm/PNP-ANALOGUE/RIGHT

MECHANICAL DATA:

15. HOUSING	ABS PLASTIC BODY DESIGNED TO DIN EN50025 SIZE 111 5mm X 40mm X 40 mm
16. MOUNTING	Dia 5.3mm FOUR THRU HOLES FOR WALL MOUNTING
15. TERMINATION	SCREW TERMINALS with COMPARTMENT SIZE 1X2.5Sq.mm

PROTECTION FEATURES:

16. ENVIRONMENTAL	IP65
17. POLARITY REVERSAL	YES

CONNECTION DETAILS:

(4)	+V
(1)	ANALOGUE O/P
(2)	0V
(5)	0V



Recommended for the application subject to manufacturer's change time to time.

**Please contact factory for different barrel lengths.

Specifications are subject to change without notice.